



FY-30A Flight Stabilization System installation & operation manual

Dear Pilot,

Thank for choosing FY30A as your inertial stabilization solution. Please read this manual carefully before using the system to ensure proper use and operation.

Note:

- The installation and use of this device require some skill and knowledge in flying remote controlled fixed wing aircraft.
- If you are a complete beginner and have never flown one before, we do not recommend you install this device on your own.
- Please find assistance from an experience RC Pilot who may provide you with the basic knowledge required to use this device successfully.
- If you are already an experienced flyer, you will find the FY30A installation to be easy and logical. Just follow this manual and you won't go wrong.

If you need any technical support kindly contact us directly:

service@feiyu-tech.com.

INTRODUCTION

FY-30A is an inertial attitude measurement instrument used for automated stabilization of fixed wing model aircrafts and two axis camera gimbals.

FY30A has an integrated three-axis gyro and three-axis accelerometer which controls the aircraft movement in three-dimensional space. By using your remote control, the unit can be turned on or off for the following functions:

❖ **Level flight** – When stabilization is activated, the FY-30A will automatically control the aircraft for smooth easy flying. For beginners in RC aircraft flying, this is advantages as it makes flight easier and increases the student pilot self-confidence. The system can be activated throughout the entire flight duration, from take off to landing.

❖ **Emergency Recovery** - If you lose orientation or feel the plane out of control, then release all control sticks, maintain throttle and switch on the FY30A. The unit will automatically send the correct signals to balance of the aircraft and regain level flight.

❖ **Aerobatics** – for the experienced fixed wing 3D pilot, the FY-30A can help you achieve a more accurate flight path, especially in windy conditions. FY-30A makes 3D maneuvers such as inverted flight, knife-edge, crane etc easier and simpler to achieve and maintain. A great way to practice and improve your 3D flying.

❖ **First Person View** - for long-distance RC flight via video transmitter, the FY30A will maintain the balance of your aircraft. You only need to control the heading of your aircraft and enjoy the view.

❖ **Firmware upgrade** – The FY30A firmware is upgradable by connecting to your computer via a USB TTL cable. As Feiyu Tech continuously improves the FY30A system, firmware upgrades will be released periodically.

How it works

The core of the FY-30A is the integrated 3-axis gyro and 3-axis accelerometer which is the basis for its inertial sensing. The FY30A is an inertial navigation platform with a strap down attitude algorithm designed for fixed wing aircraft stabilization.

When the FY-30A is in auto-balance mode, it detects the aircraft attitude and horizontal positioning and issues commands to servos that adjust the aircraft control surfaces (Aileron, Elevator and Rudder) so that the aircraft remains level at all times. Due to this autonomous action to maintain smooth level flight, the FY-30A makes flying very easy.

When the FY-30A is operating in 3D mode and the aircraft is in an acrobatics flight, the FY30A will use the 3-axis gyroscopes to calculate roll velocity and overall flight attitude. With this data, the system outputs control corrections to maintain smooth aircraft attitude even when doing aerobatics flight.

Since the FY30A is self contained, it can be used in all weather conditions, indoors or outdoors. Just power up and take off.

Aircraft Suitability

The FY30A can be used in the following fixed wing models:

- Traditional layout fixed-wing aircraft with

Aileron, Elevator and Rudder;

- Flying wings with rudder and with no rudder;
- Airplanes with no ailerons (rudder and elevator only)
- V-tail airplanes with aileron and with no ailerons
- Any other configuration inquiries, please email us:

service@feiyu-tech.com.

RC Radio suitability:

The FY-30A has been tested to work well with the following RC system:

- Robbe-Futaba PPM / PCM 1024 / PCM G3 mode, 2.4G systems;
- Graupner / JR PPM 8, PPM 12, SPCM mode;
- MPX PPM8, PPM 12 with UNI mode;
- Any other system with a neutral position of 1.5 ms (standard in most RC Radios).

FY-30A Operating Mode

The FY-30A can be operated in three flight modes:

• **Mode 1: FY-30A Deactivated Mode.** In this mode, the FY-30A stabilization function is turned off. The aircraft is completely under the control of the pilot.

• **Mode 2: 3D Control Mode.** In this mode, the balancer utilizes its 3-axis gyroscope to sense roll velocity and flight attitude. If no input is given by the pilot (sticks in the middle position) the FY30A will lock the current aircraft attitude. This prevents rolling of the aircraft at the axial plane and maintains its current posture. Therefore the aircraft can be easily maneuvered to complete a variety of 3D flight with added stability and smoothness.

• **Mode 3: Auto Stabilization mode.** In this mode, the FY-30A will automatically command the aircraft control surfaces to maintain level flight at all times.

Switch Setting for FY-30A Flight Modes

- To activate the different flight modes, use a free Receiver channel (e.g. Channel 5) to output the appropriate signal to the FY30A.
- Use a 3 way-switch from your RC radio as in the example at right:

RC Receiver Signal output:

Switch setting example

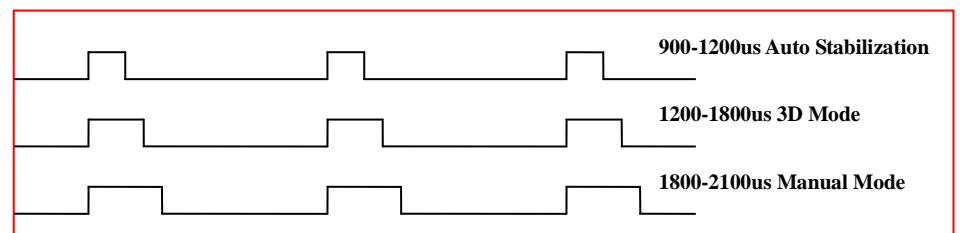

Flight Modes	MODE 3	MODE 2	MODE 1
Receiver signal output	900-1200uS	1200-1800 uS	1800-2100 uS
FY30A Function	Auto Stabilization mode	3D Mode	Manual Mode

c) You may use a 2-position switch, setting the maximum and minimum End Points (EPA) to activate or deactivate flight stabilization (omitting 3D-Mode).

d) If you do not connect the Switch channel to your RC Receiver or the FY-30A does not detect any incoming signal through this input channel, it will automatically engage Mode 3- Auto Stabilization Mode. However, we do not recommend flying the unit with no signal input to the Switch Channel.

e) Please note that even though there is a Throttle Input and Throttle Output from the FY30A, the system does not overlay any throttle control quantity. As to say, the FY-30A is just used for signals connecting. As a pilot, you must always ensure your aircraft has enough cruising speed to prevent stall.

f) **Warning:** The Auto Stabilization Mode will provide a smoother leveled landing for your aircraft. However, note that the turning radius is larger when in this mode. Please ensure your landing area has adequate clearance for this larger radius.

FY-30A interface

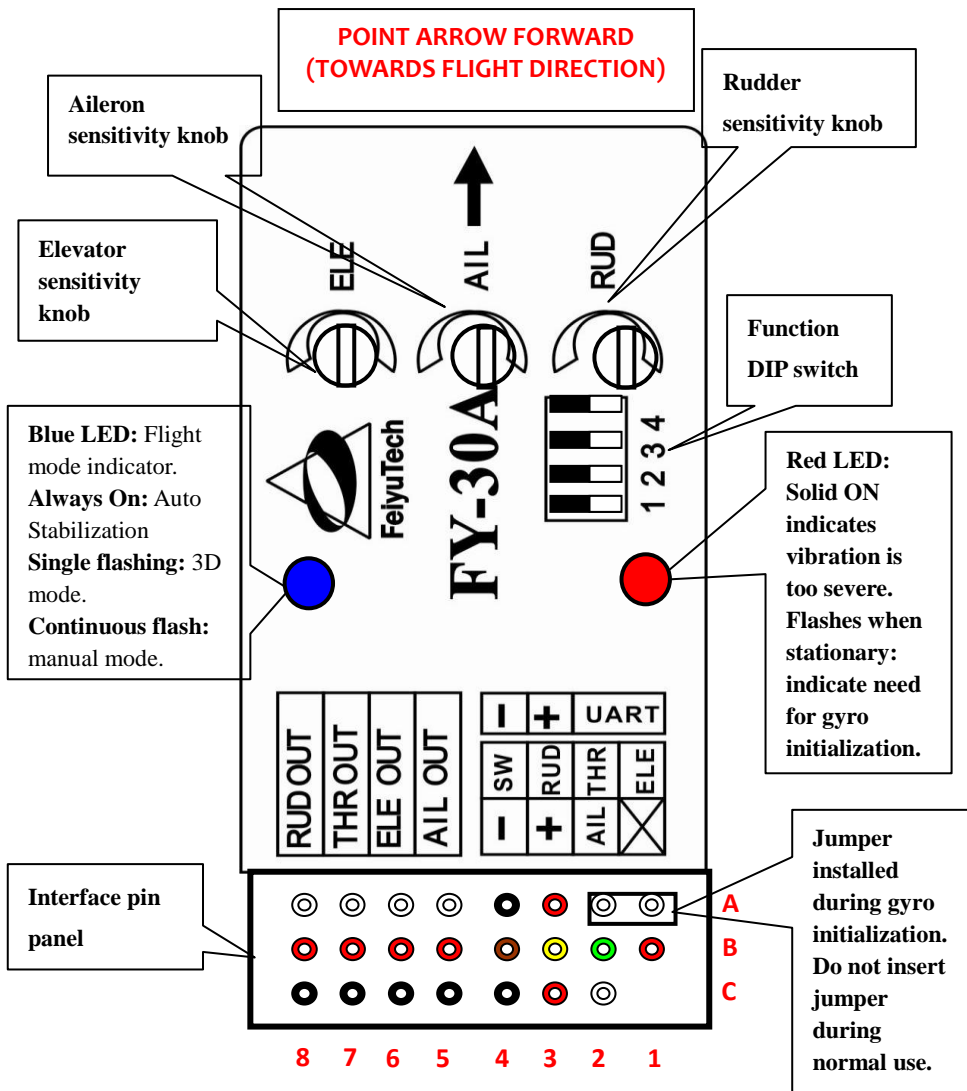

Pin interface to sort the list

8	7	6	5	4	3	2	1	N O.
Rudder out	Throttle out	Elevator out	Aileron out	Ground	Power	TX	RX	A
Power	Power	Power	Power	CH5 (Switch)	CH 4 (Rudder)	CH 3 (Throttle)	CH 2 (Elevator)	B
Ground	Ground	Ground	Ground	Ground	Power	CH 1 (Aileron)	NULL	C

DIP Switch Function:

Switch number	1	2	3	4
ON	For Factory use only	Flight Mode Selection	Flight Mode Selection	Adjust flight patterns
OFF	Always OFF position	Flight Mode Selection	Flight Mode Selection	Normal mode

Blue LED

Blue LED	Continuous flashing	On Solid	DIP Switch Setting
Flight Mode Status	manual mode	Auto Stabilization	3D mode

Red LED

Red LED	OFF	Aircraft is stationary but Red LED Flashes	ON Solid
Status Indicator	Normal	Need to initialize the gyro	High Vibration Detected. Does not meet system requirement.

Gyroscope initialization (re-setting):

Out of the box, the FY-30A has been fully initialized. However, if the following conditions occur, resetting the gyro is recommended:

1. The device has not been used for a long time.
2. There is a change in environmental temperature of over 30 degrees.
3. When the red LED light flashes even when the aircraft is stationary.

Initialization / Reset Procedure

Install the jumper as shown in this picture:

Power-ON the FY-30A and keep it stationary for at least 20 seconds.

You will notice the red light blink at two different rates (or turns off). Gyro re-setting is complete. Disconnect power, unplug the jumper and keep it in a safe place for future use).

8 7 6 5 4 3 2 1

A
B
C

NOTE:

• Carry out this re-setting procedure only if the 3 conditions (above) occur. It is not recommended to regularly reset the gyro. It is not necessary.

• The stabilizer unit does not need to be in a horizontal position during initialization. However, you must ensure there is no vibration during this process. If you suspect shaking had occurred, just restart the resetting process.

FY30A power supply

- FY30A working voltage = 5 to 6V.
- The FY30A require stable power input. Therefore, we highly recommend using an External BEC power supply with minimum 3A output. The higher the better.
- Be sure to remove the Red wire from your ESC plug if using an external BEC.
- BEC should be plugged into your RC Receiver. Power is sent to the FY-30A via Channel 1 input.
- FY-30A colour coded cable to RC Receiver:

RC Receiver Requirement

- a) FY-30A require at least a 5 channel receiver
- b) Plug in the cable into the FY30A and connect to the RC Receiver following these colour codes:

Wire color	Receiver channel	
White (red and black)	Aileron	Channel 1
Orange	Elevator	Channel 2
Green	Throttle	Channel 3
Yellow	Rudder	Channel 4
Brown	Controlled via 3-Way or 2-Way switch	

- c) Note Channel 5 will output the signal to control the 3 flight modes of the FY-30A. Therefore assign a 3-way or 2-way switch to this channel.

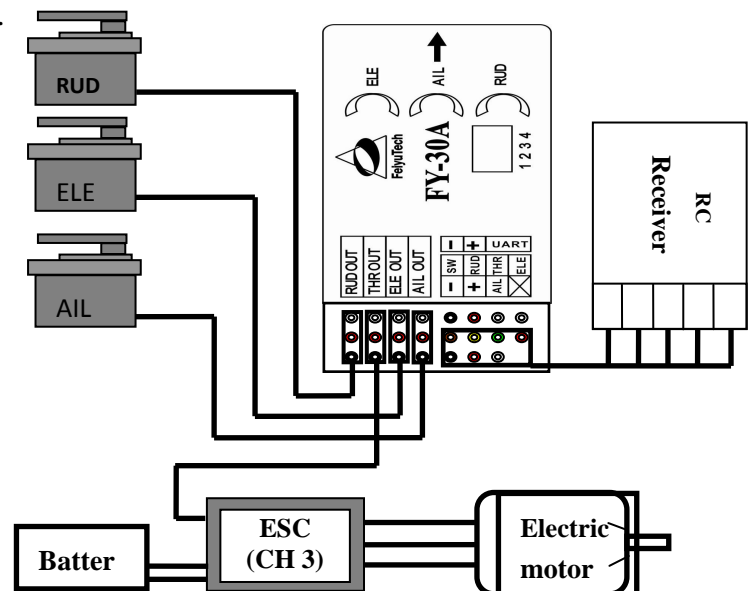

DIP Switch Setting

a)FY30A connection for traditional aircraft layout:

AIL OUT	ELE OUT	THR OUT	RUD OUT	ON
Aileron servo	Elevator servo	ESC	Rudder servo	OFF

1 2 3 4

b)FY30A connection for flying wing aircraft (with or without Rudder):

AIL OUT	ELE OUT	THR OUT	RUD OUT	ON
Differential Servo 1	Differential Servo 2	ESC	Rudder servo	OFF

1 2 3 4

c) FY30A connection for V tail aircraft with Aileron:

AIL OUT	ELE OUT	THR OUT	RUD OUT
Aileron servo	Differential Servo 1	ESC	Differential Servo 2



d) FY30A connection for V tail aircraft without ailerons:

AIL OUT	ELE OUT	THR OUT	RUD OUT
Differential Servo 1	Differential Servo 2	ESC	NULL

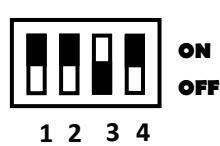

e) FY30A connection for traditional layout aircraft with no Aileron:

AIL OUT	ELE OUT	THR OUT	RUD OUT
Rudder servo	Elevator servo	ESC	Null



f) Camera Gimbal Stabilization;

AIL OUT	ELE OUT	THR OUT	RUD OUT
Roll Servo	Tilt Servo	NULL	Pan Servo

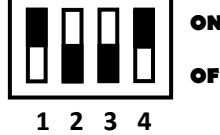

* **Note:** The camera gimbal Roll, Tilt and Pan servos will counter any linear movement of the camera mount. You can move the camera at any angle and upon releasing the stick, the FY30A will maintain stabilization at that angle.

FY-30A and Vibration Control

- a) FY-30A is vibration-sensitive. To optimize its stabilization capability, vibrations reaching the unit must be kept at a minimum.
- b) When installing this flight stabilizer, we highly recommend that you install it with the supplied vibration absorbing pads (dampers).
- c) The algorithm in the FY-30A compensates for normal levels of flight vibration. However, if the vibration experienced by the unit exceeds the acceptable level, it will not work normally or may even stop working altogether.
- d) To keep vibration at a minimum, install the FY-30A away from the engine or any other vibration sources.
- e) The included shock-absorbing pads will meet the damping requirements for electric powered aircrafts and most gas / nitro planes.

How to check installation requirements to meet the shock

Even with the shock absorbing mount, your aircraft installation may not meet the damping requirements of the FSS. To confirm correct vibration damping, please follow this procedure:

- A. After connecting all wires between the Receiver, FY-20A and Servos, install the unit as recommended (ensure correct orientation).
- B. Run the plane engine or motor at different throttle levels. **DO NOT TAKE OFF.**
- C. Move the throttle level to different positions and maintain it for 20 seconds at each position.
- D. At each throttle position, observe the state of the red LED light. If it stays OFF, that means your vibration level is acceptable.
- E. If instead the red LED lights up brightly and stays ON solid, then the vibration dampening is not enough. You will need reduce the level of vibration on your aircraft, add additional dampening support or change the installation location.

F. **Vibration Security:** An updated feature of the FY-30A is emergency stabilization in case of sudden high vibration during flight. In such a situation, the FY-30A will automatically activate the highest level of stabilization and therefore withstand vibration better. This feature should allow you to safely return the plane for an emergency landing.

Fy-30a Installation: Orientation, Position & Level

- i. The FY-30A has an arrow printed on the top of it. Orient the arrow towards the front of the craft (i.e. direction of flight).
- ii. When installing, please keep the FY-30A horizontal and as close as possible to the "Centre of gravity" (C o G) of the aircraft.
- iii. The benchmark for the FY-30A is its horizontal position. Therefore, physically adjust the FY-30A into horizontal position when the plane is in level flight:

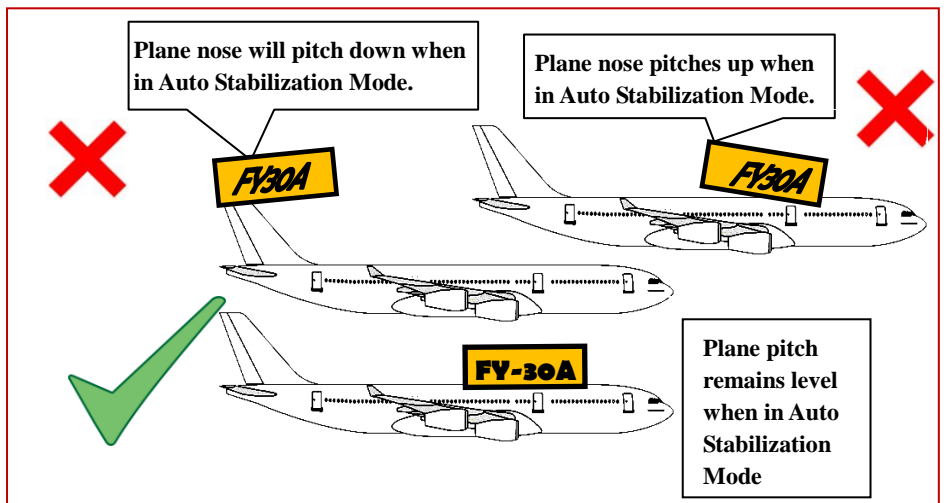
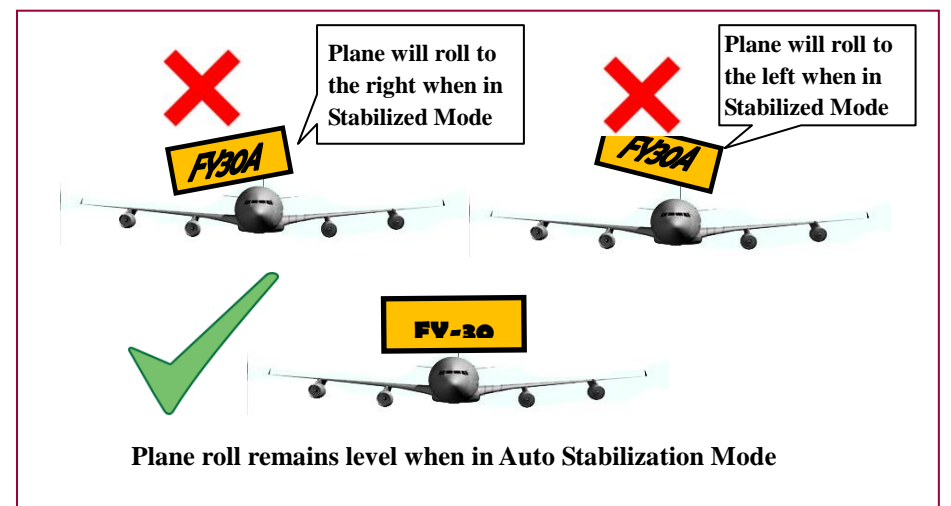

iv. If there is deviation between the FY-30A horizontal position and the plane's level flight, it may cause the neutral value to be different between the Manual Mode and the auto Stabilized Mode. See next topic.

Adjustment Dials for ELE, AIL and RUD

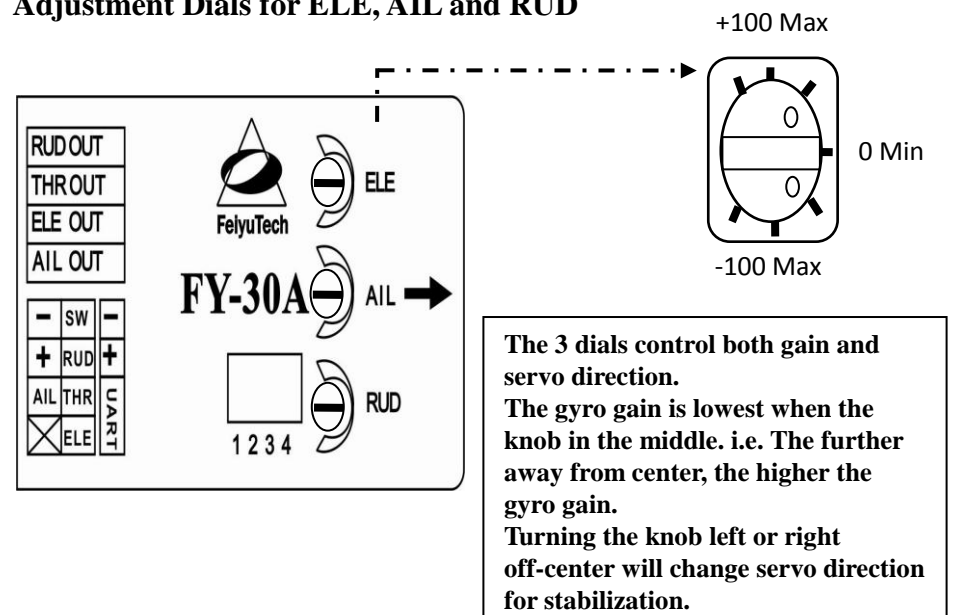

1. There are 3 adjustment dials on the FY30A. Each dial controls **both** gyro gain **and** servo direction during auto stabilization.

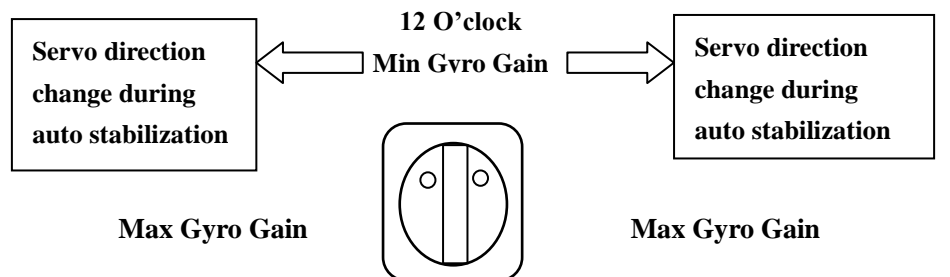

2. **Gyro Gain:** The further away from Centre (12 O'clock) the higher the Gyro gain (sensitivity). Too low gain result is poor auto stabilization, too high gain will cause oscillations of the aircraft. You need to adjust the gain setting based on the requirement of your aircraft.

3. **Servo Direction:** The dials also control the direction of your servo movement. Turning it clockwise or counter clockwise from 12 O'clock will change the direction of your servos during tilting, roll and yaw movement.

FY-30A Pre-flight Set Up

Install FY30A as recommended in this manual, then proceed with pre-flight setup:

- 1. Confirm that the control surfaces do not move when the aircraft is tilted and the FY30A is in Mode 1 (Manual mode).
- 2. Activate Mode 3 (Auto stabilize mode) and observe the movement direction of Aileron, Elevator and Rudder. The direction should be as shown below. If it does not, turn the appropriate dial to the opposite side

of 12 O'clock. Confirm the movement is now correct:

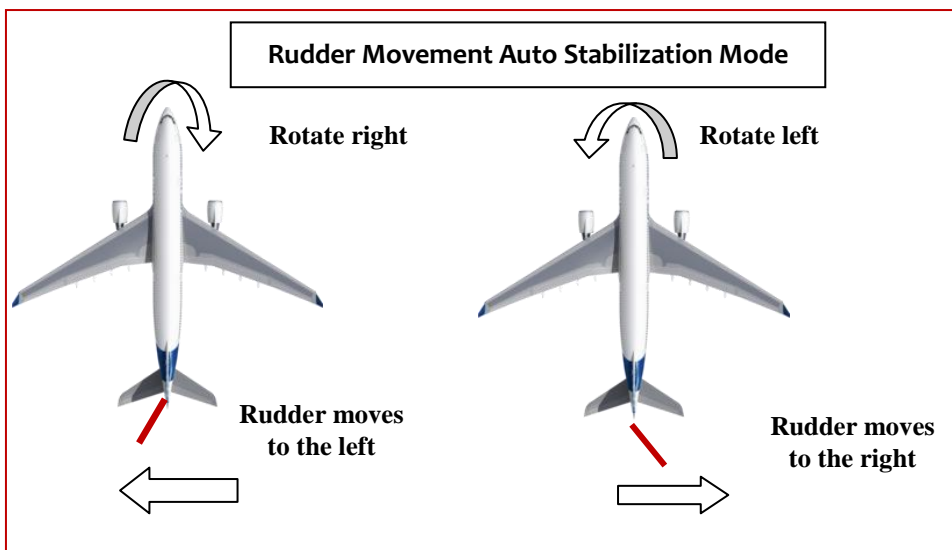
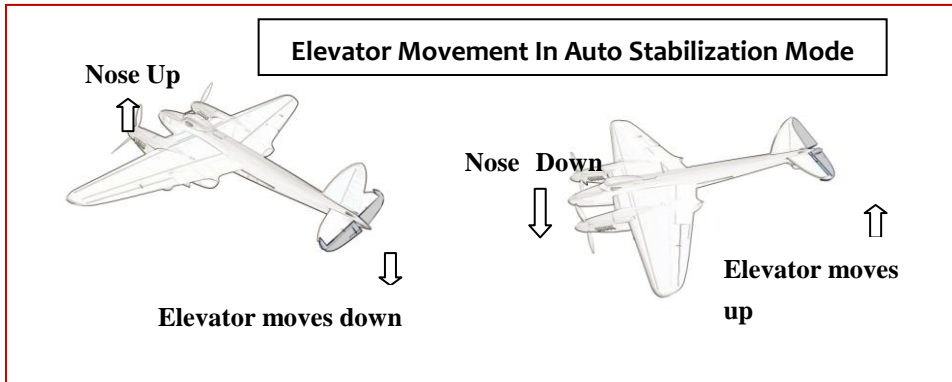
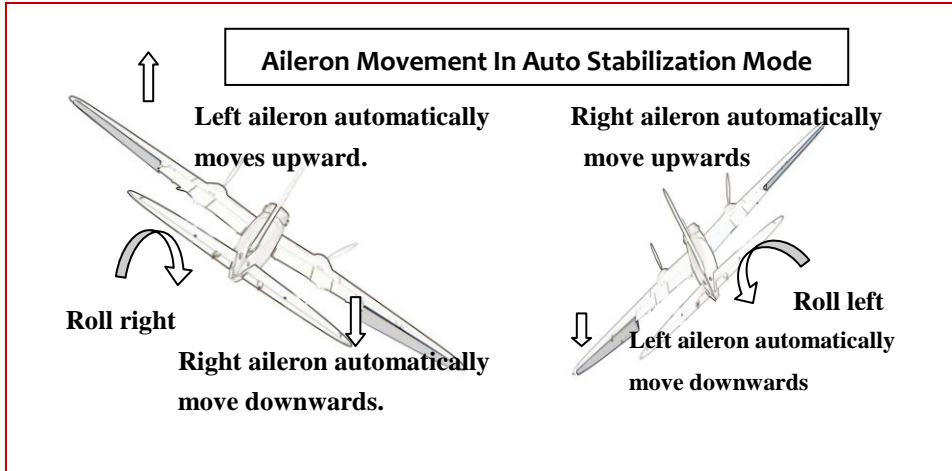

First Flight Test And Sensitivity Adjustment

- At this stage, your aircraft should already have automated surface control with the right direction when in (Mode 3) Auto Stabilized Mode enable.
- Now you need to fine tune your FY30A stability gain via flight tests. For the first flight it is recommended that the gains not be set too high. This will reduce large oscillation (flight overcorrection).
- Take off in Mode 1 (deactivated). After achieving safe height, activate Mode 3 (Auto Stabilized).
- Aileron Gain:** If you see oscillation of the wings, this indicates the Aileron gain is set too high. Switch back to Mode 1 (deactivated) and land the airplane.
- Reduce the sensitivity (move dial towards centre position) and fly again. You should see improvement in wing attitude. Adjust until you are satisfied with the level of wing stabilization.
- Elevator & Rudder Gain:** Too much Elevator gain will show the tail moving up and down (rocking). Too much Rudder gain will show tail wagging. Reduce gain until this flight over corrections disappears.
- Alternately, if you find the flight correction is not enough (too low stability), you can increase gain accordingly.

Recording your Aircraft Attitude (Dip Switch No. 4)

- The FY30A can record your aircraft best stabilization attitude in its memory.
- This is advantageous as each aircraft is unique in terms of attitude control. By recording your aircraft 'Neutral Value', the FY30A can know how best to control your aircraft for optimum stability.
- It is best to carry out this procedure during minimal wind conditions:

Step 1: Set up your aircraft as per this manual for stabilized flight, including setting the right gain for the 3 dials. ON

Step 2: Land and power down the aircraft. Move Dip Switch No. 4 to 'ON' position. OFF

Step 3: Take off again, in full manual control (Mode 1 –

Deactivated Mode). Fly to a safe height and **in a straight line**.

Step 4: Adjust your throttle to maintain stable cruising flight. Use your Aileron, Rudder and Elevator trims to attain level flight while in manual control. By doing this you should be able to fly the aircraft in a straight line with the Aileron, Elevator and Rudder sticks in the middle position (i.e. fly using trims only).

This condition of achieving level flight by trim adjustments and no stick input is your aircraft's '**Neutral Value**'.

Step 5: While in Neutral Value, activate Mode 3 (Auto Stabilization Mode). Since Dip Switch No. 4 is ON, the FY30A will now record your Neutral Point. Recording takes about 3 seconds. After 3 seconds, switch back to manual mode and land your aircraft. 1 2 3 4

Step 6: After landing, power down your aircraft. Move Dip Switch No. 4 back to OFF position. Procedure is complete.

4. As long as there are no major changes in your aircraft hardware (e.g. no shifting of C o G) your Neutral Value will not change. If there are major changes in hardware or your CoG have shifted, it is best you repeat this Neutral Value recording procedure.

FY-30A attitude data output

FY-30A Outputs pitch angle and roll angle data via data port (UART) output. The interface position as shown below:

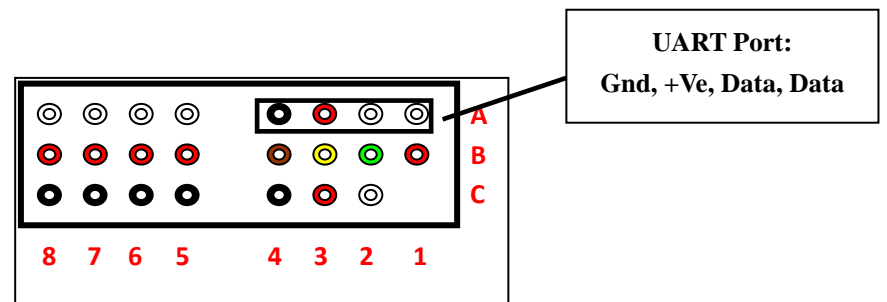

Data from the header and data segments, each field separated by commas.

Standard serial interface characteristics:

Baud Rate: 19200

Level: TTL

Command Types	Command header	Field 1	Field 2	Field 3	Field 4	Field 5	Field 6
Attitude data	\$FYZT	Pitch (Unit: degrees)	Roll (Degrees)	Course (Degrees)	X Angular velocity (Degrees)	Y Angular velocity (Degrees)	Z Angular Velocity (Degrees)
Field 7	Field 8	Field 9	Field 10	Field 11	Field 12	Field 13	Check
Unused	Unused	Unused	Resultant acceleration	Unused	Unused	Attitude error	To test the value of 00

Example of UART Data Output:

\$FYZT,-0.98, 0.12, -0.08, -0.05, -0.31, 0.10, , , , 1.01, , , 0*00

Interpretation:

Profile format	\$FYZT	Pitch	Roll	Course	X Angular velocity	Y Angular velocity	Z Angular Velocity
Data		-0.98	0.12	-0.08	-0.05,	-0.31,	0.10
Unused	Unused	Unused	Resultant acceleration	Unused	Unused	Attitude error	* Test value
			1.01			0	00

-END-